

## Design and static structural analysis of engine hood using different materials

**Chukka Rajesh<sup>1</sup>, Pulletikurthi Surya<sup>2</sup>, Mortha Babji<sup>3</sup>, K Ashok vamsi<sup>4</sup>**

<sup>1</sup>Machine design, M tech student, Department of Mechanical engineering Srinivas engineering college NAAC A, Autonomous, cheyyeru (v), Amalapuram, Andhra Pradesh- 533216

<sup>2</sup>Assistant professor, Head of the Department of Mechanical engineering, Srinivas engineering college NAAC A, Autonomous, cheyyeru (v), Amalapuram, Andhra Pradesh- 533216

<sup>3,4</sup>Department of Mechanical engineering, Srinivas engineering college NAAC A, Autonomous, cheyyeru (v), Amalapuram, Andhra Pradesh- 533216

**Email id:** rajeshchukka3013@gmail.com<sup>1</sup>, pulletikurthisurya@gmail.com<sup>2</sup>,  
babjimech303@gmail.com<sup>3</sup>, ashok.chinni599@gmail.com<sup>4</sup>

### Abstract

The engine hood of an automobile plays a vital role in protecting engine components while ensuring the safety of passengers and pedestrians. It must strike a balance between providing easy access for maintenance and maintaining adequate rigidity under both operational and impact conditions. In recent years, the use of composite materials has gained considerable attention in the automotive and aerospace industries due to their lightweight, high strength, environmental sustainability, and superior mechanical properties. This study focuses on the design and static structural analysis of an engine hood, utilizing SolidWorks 2026 for design and ANSYS 16.0 for static structural analysis. Three materials Epoxy Carbon, CFRP, AISI 1080 were considered for the analysis. Key parameters such as total deformation, equivalent (von Mises) stress, and equivalent elastic strain were assessed to evaluate the performance of each material in real-world conditions. The results provide insights into the advantages and limitations of each material, offering a comparative view of their suitability for engine hood design in terms of strength, durability, and weight reduction.

**Keywords:** Engine Hood, Static Structural Analysis, SW 2026, ANSYS 16.0

### 1. Introduction

The engine hood is a critical component in automotive design, serving both functional and safety purposes. It provides protection to the engine parts from environmental factors, debris, and impact during accidents, while also contributing to pedestrian safety. Additionally, the engine hood must allow for easy access to the engine during maintenance and repair, without compromising the structural integrity of the vehicle under operational and crash conditions. As vehicles continue to evolve, engineers are increasingly turning to advanced materials to optimize the performance and efficiency of automotive components, including the engine hood. Traditionally, steel has been the primary material used for engine hoods due to its strength, durability, and cost-effectiveness. However, with the growing emphasis on reducing vehicle weight for improved fuel efficiency and performance, lighter materials such as aluminum alloys and composites have become more prominent in automotive engineering. Aluminum alloys, known for their excellent strength-to-weight ratio, provide a lightweight alternative to steel

while maintaining durability. On the other hand, carbon fiber composites, with their exceptional strength and stiffness, offer even greater weight reduction but at a higher cost.

### Engine Hood

The engine hood, also known as the bonnet in some regions, is an essential part of an automobile, serving as a protective cover for the engine compartment. It is designed to shield the engine components from external environmental factors, such as dirt, debris, and moisture, while also protecting the vehicle's occupants and pedestrians during accidents. As a structural component of the vehicle, the engine hood plays a key role in maintaining the overall safety and integrity of the automobile. Beyond its protective function, the engine hood is also critical in providing easy access to the engine for routine maintenance and repairs. It must allow for quick opening and closing mechanisms while ensuring that the vehicle's structural integrity is not compromised during high-impact situations. The material and design of the engine hood are key factors that influence its performance in terms of weight, strength, durability, and safety features.

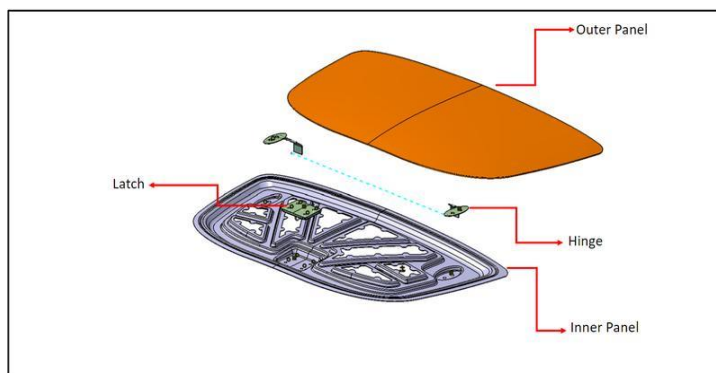

**Figure 1: Engine Hood**

The above figure illustrates the engine hood (bonnet) of an automobile, showing its main components such as the outer panel, inner panel, reinforcement ribs, hinges, and latch system. The outer panel provides the visible surface and aerodynamic shape, while the inner panel and ribs offer structural strength and stiffness. The hood is designed to protect engine components, allow easy access for maintenance, and ensure safety by absorbing impact energy during collisions.

### Advantages of Engine Hood

The engine hood is a vital component of a vehicle, offering several key advantages. It protects the engine and critical components from environmental elements like dirt, debris, and moisture, ensuring their longevity and functionality. The hood also enhances passenger and pedestrian safety by absorbing impact energy during collisions.

- **Protection of Engine Components:** The engine hood acts as a shield, protecting the engine and other critical components from dirt, debris, water, and environmental factors, ensuring their longevity and efficient functioning.

- **Passenger and Pedestrian Safety:** In the event of a collision, the engine hood helps absorb impact energy, reducing the risk of injury to both passengers inside the vehicle and pedestrians outside.
- **Ease of Maintenance:** The engine hood provides easy access to the engine compartment, allowing mechanics and vehicle owners to perform maintenance and repairs with greater convenience.

## 2. Literature Review

The Evolution of Material Technology in Automotive design has significantly impacted the performance, safety, and manufacturing processes of vehicle components, particularly the engine hood. The selection of materials for engine hoods has always been a crucial consideration for manufacturers, and a wide body of research has explored the trade-offs between material properties such as strength, weight, durability, and cost. According to **Zhang et al. (2019)**, traditional materials like steel and aluminum alloys have long been the mainstay in automotive manufacturing due to their proven strength and cost-effectiveness. However, their research highlights the growing demand for lightweight materials, particularly aluminum alloys, which can significantly reduce the overall weight of vehicles without compromising safety. In a similar study, **Smith and Lee (2020)** explored the advantages of using carbon fiber composites in high-performance vehicles, emphasizing the material's excellent strength-to-weight ratio. Their findings suggest that carbon fiber, despite its higher cost, offers superior performance in terms of rigidity, durability, and crash safety. Building on these materials, **Williams et al. (2021)** Their research demonstrated that hybrid materials could offer the best of both worlds: the strength and affordability of metals combined with the lightweight and corrosion-resistant properties of composites. In contrast, **Roberts et al. (2018)** focused on the cost implications of using advanced materials in mass production. They highlighted the challenges faced by the automotive industry in adopting high-cost materials like carbon fiber, particularly in terms of manufacturing processes. Lastly, **Cheng and Li (2022)** explored the environmental implications of material selection for engine hoods, particularly focusing on the recyclability and sustainability of materials. **Davis et al. (2020)** investigated the role of advanced composite materials such as carbon fiber and glass fiber in reducing vehicle weight while improving strength and safety. Building on material strength and safety, **Patel and Kumar (2021)** focused on aluminum alloys for engine hoods, particularly in electric vehicles (EVs). Their study emphasized the importance of reducing vehicle weight to improve battery efficiency and extend the driving range of electric cars. Aluminum, with its high strength-to-weight ratio, emerged as a preferred material in the EV industry. The environmental aspects of material selection were further explored by **Martin et al. (2021)**, who focused on the life cycle assessment (LCA) of different materials used for engine hoods. Their findings indicated that while carbon fiber is often associated with high performance, it has a significantly higher environmental cost during production compared to metals such as aluminum and steel. The manufacturing process for engine hoods made from composite materials was examined by **Singh and Mehta (2022)**, who analyzed cost-effective production techniques. Their research explored how the use of resin transfer molding (RTM) and vacuum-assisted resin infusion (VARI) could optimize the production of composite engine hoods, reducing costs while maintaining the desired strength and performance. Lastly, **Jackson et al. (2023)** focused on the impact resistance of materials used for engine hoods, particularly in the context of pedestrian

safety. Their study investigated how materials such as steel, aluminum, and composites behave during low-speed collisions, a critical aspect of pedestrian safety.

### 3. Methodology

The primary goal of this study is to design an engine hood using three different materials Epoxy Carbon, CFRP, and AISI 1080 and perform static structural analysis to evaluate their performance under real-world conditions. The materials are selected based on their mechanical properties, with an emphasis on lightweight characteristics, high strength, and durability. The design will be created using SolidWorks 2026, while static structural analysis will be carried out using ANSYS 16.0.

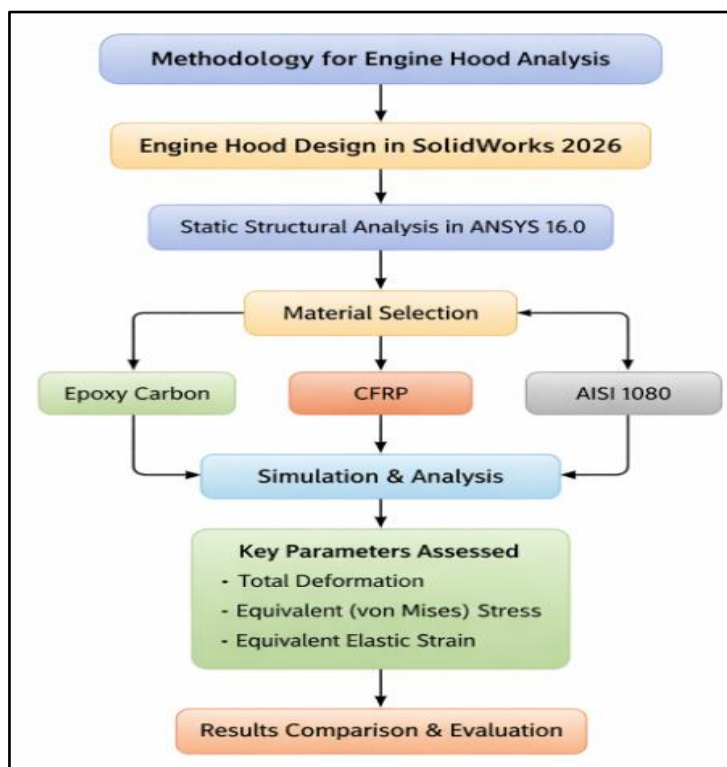

**Figure 2:** Design flow chart

#### Engine hood working principals

- **Protection:** The primary function of the engine hood is to protect the engine and other vital components of the vehicle from external elements like dirt, debris, and weather conditions. It acts as a barrier to shield the engine bay from dust, moisture, and contaminants.
- **Structural Integrity:** The engine hood is designed to provide structural integrity and strength to the vehicle's front end. It ensures that, in case of an impact (e.g., during a collision), the engine compartment and the occupants are protected from excessive damage.
- **Heat Dissipation:** The engine generates significant heat during operation, and the hood plays a crucial role in heat dissipation. Most engine hoods are designed with vents or louvers to allow for proper airflow and heat removal, preventing the engine from overheating.

- **Accessibility:** The engine hood is designed for easy access to the engine and other mechanical components. This allows mechanics and vehicle owners to perform regular maintenance tasks, such as oil changes, fluid checks, and repairs.
- **Safety:** The hood must also be designed to minimize injury risk during accidents. For example, the latch and release mechanism should allow for quick and easy opening in case of emergencies, while the hood itself is built to withstand impact without causing harm to passengers.

### Design model

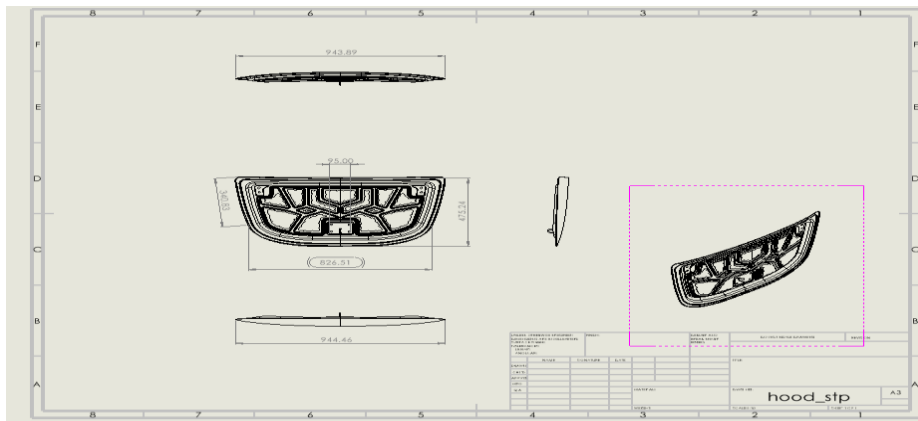

**Figure 3: Geometry model**

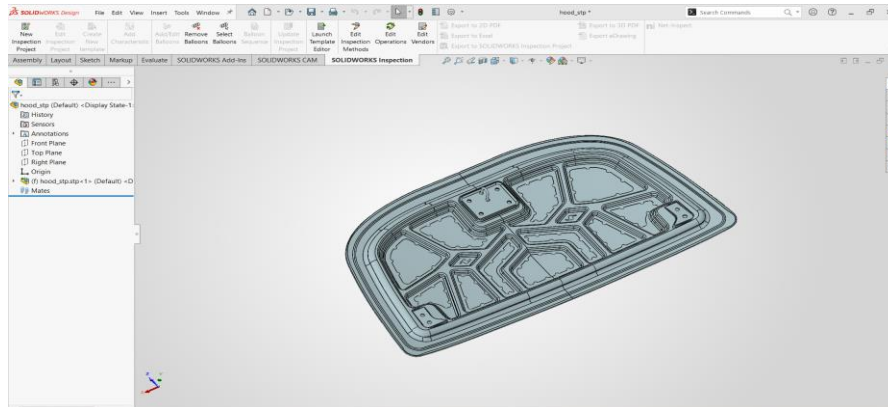

**Figure 4: Engine hood design model**

The figure presents the three-dimensional CAD model of the automotive engine hood developed using SOLIDWORKS. The model represents the inner panel structure of the hood and incorporates a network of strategically designed reinforcement ribs to enhance structural strength while reducing overall component weight.

## 4. Results And Discussions

In their study to discuss the structural analysis of a shock absorber in ANSYS 16.0, subjected to a 100 N applied load using three materials: Epoxy Carbon, CFRP, and AISI 1080.

### Static structural analysis of engine hood using Epoxy Carbon:

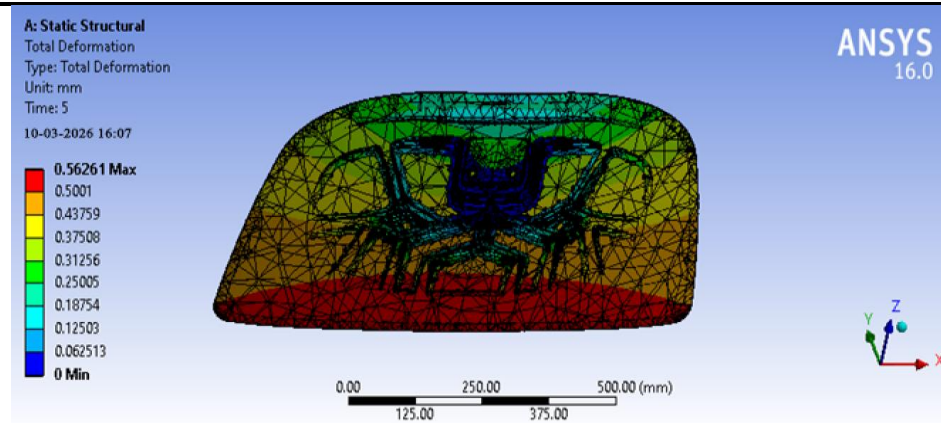

**Figure 5: Total deformation**

The maximum total deformation value shown in the figure is 0.56261 mm, which is represented by the red region on the color map. This deformation occurs at the point experiencing the highest displacement under the applied loads in the static structural analysis of the engine hood. This value is essential for understanding the material's ability to maintain structural integrity under stress

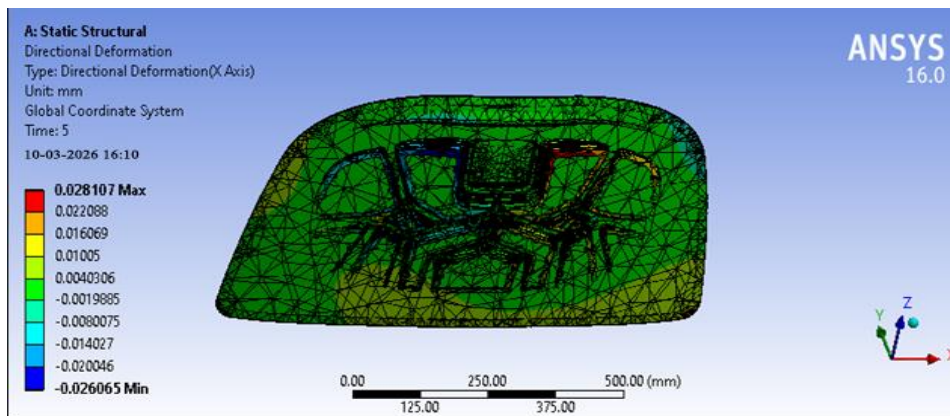

**Figure 6: Directional deformation**

The figure above shows the directional deformation in the X-axis of the engine hood during static structural analysis. The maximum directional deformation is 0.028107 mm, represented in red, while the minimum deformation is -0.026065 mm.

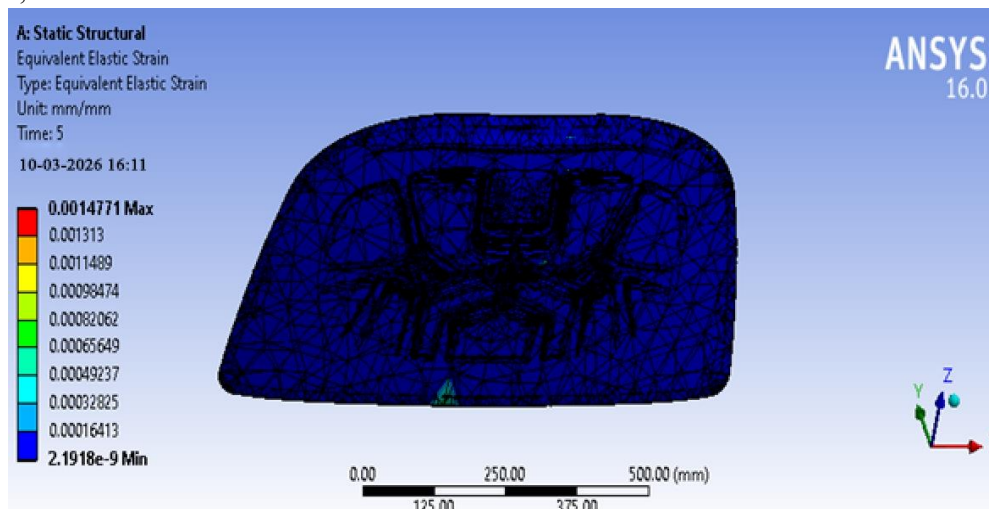

**Figure 7: Equivalent Elastic strain**

The figure above shows the equivalent elastic strain of the engine hood during static structural analysis. The maximum equivalent elastic strain value is 0.0014711 mm/mm, indicated by the red region, while the minimum strain is 2.1918e-9 mm/mm, shown in blue. This analysis helps evaluate how the material deforms elastically under applied loads, which is essential for determining the structural integrity of the engine hood and ensuring that the material can handle stresses without permanent deformation

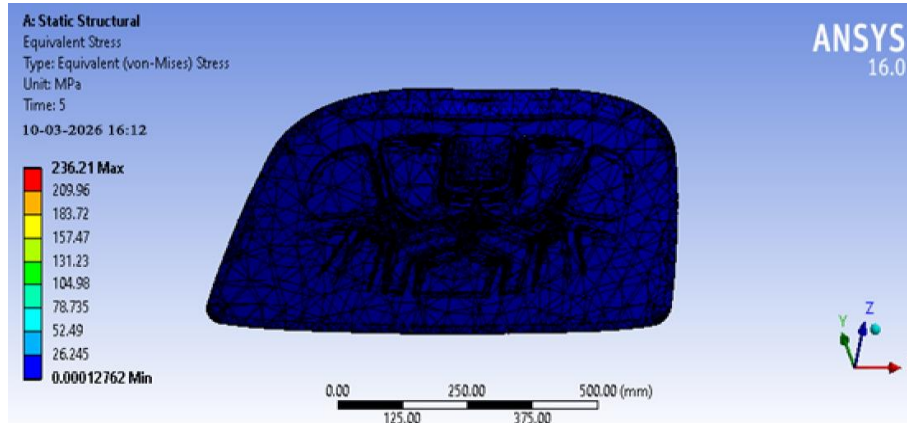

**Figure 8: Equivalent Stress**

The figure above displays the equivalent (von-Mises) stress distribution in the engine hood during static structural analysis. The maximum equivalent stress is 236.21 MPa, shown in the red region, while the minimum stress is 0.00012762 MPa, represented by the blue area.

**Static structural analysis of engine hood using CFRP Material**

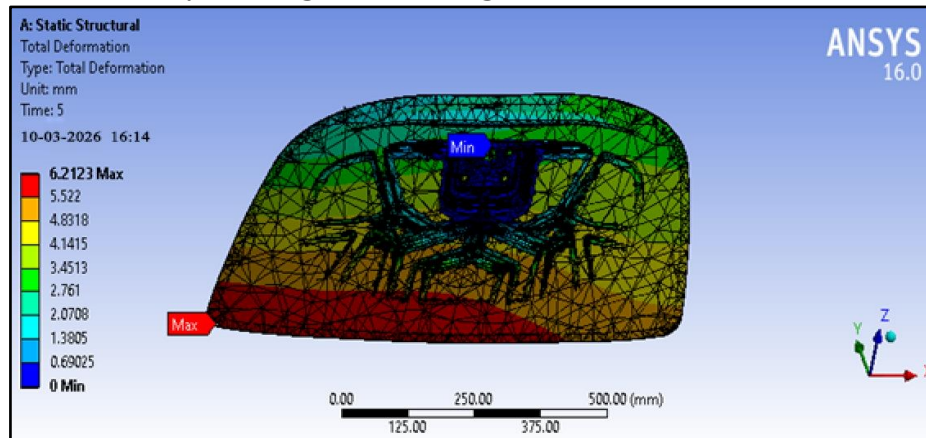

**Figure 9: Total deformation**

The figure above represents the total deformation in the engine hood structure during static structural analysis using CFRP material. The maximum total deformation value is 6.2123 mm, indicated by the red region, while the minimum deformation is 0 mm, shown in the blue area.

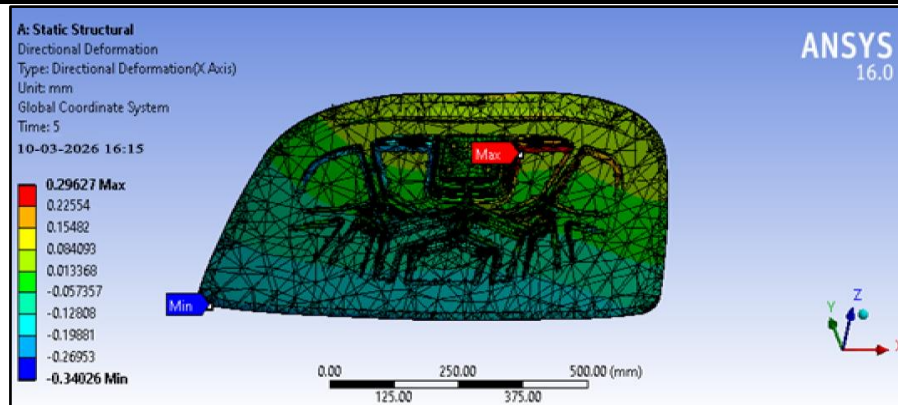

**Figure 10: Directional deformation**

The figure above shows the directional deformation in the X-axis of the engine hood structure during static structural analysis using CFRP material. The maximum directional deformation value is 0.29627 mm, indicated by the red region, while the minimum deformation is -0.34026 mm, shown in the blue area.

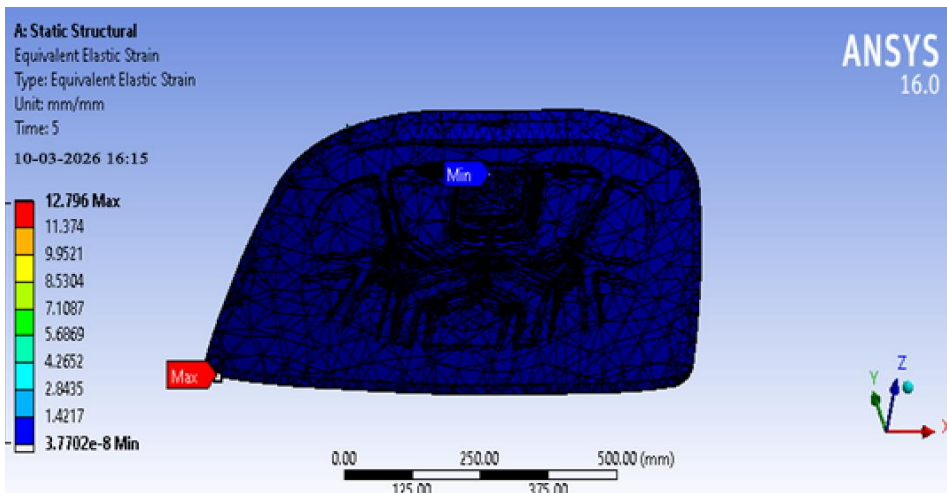

**Figure 11: Equivalent Elastic strain**

The figure above displays the equivalent elastic strain in the engine hood structure during static structural analysis using CFRP material. The maximum equivalent strain value is 12.796 mm/mm, represented by the red region, while the minimum strain is 3.7702e-8 mm/mm, shown in the blue area. This analysis helps assess how the CFRP material deforms elastically under the applied loads.

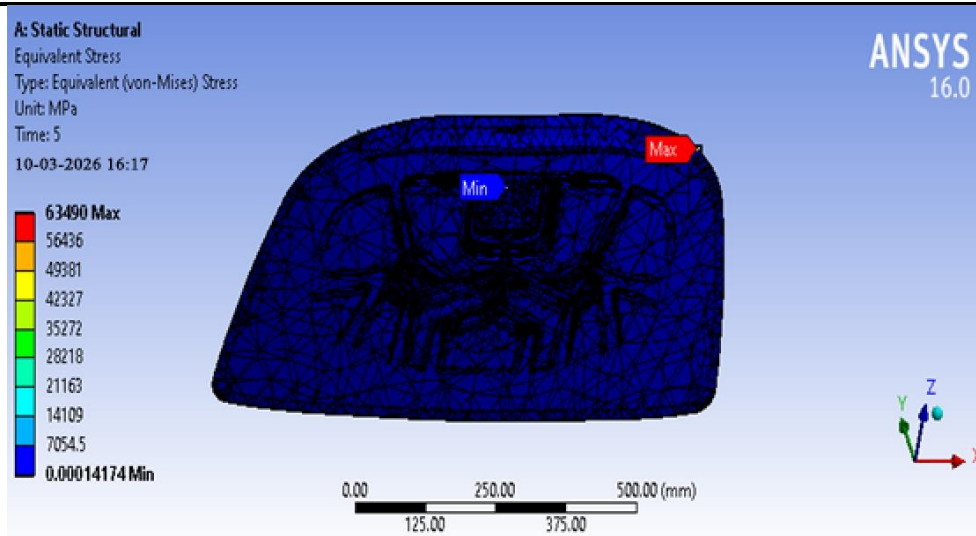

**Figure 12: Equivalent Elastic Stress**

The figure above illustrates the equivalent (von-Mises) stress distribution in the engine hood structure during static structural analysis using CFRP material. The maximum equivalent stress value is 63,490 MPa, represented by the red region, while the minimum stress is 0.00014174 MPa, indicated by the blue area. The von-Mises stress helps in identifying areas where the material may yield or fail under applied loads.

**Static Structural Analysis of Engine Hood Using AISI 1008 Material**

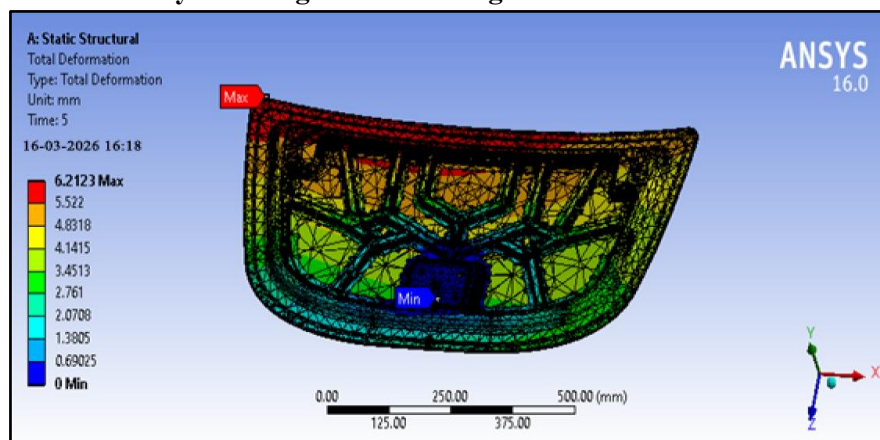

**Figure 13: Total deformation**

The figure above represents the total deformation in the engine hood structure during static structural analysis using AISI 1008 material. The maximum total deformation value is 6.2123 mm, shown in the red region, while the minimum deformation is 0 mm, indicated in the blue area. This deformation analysis helps assess how the engine hood deforms under applied loads, ensuring that the material, AISI 1008, maintains its structural integrity and performs within acceptable limits in real-world conditions.

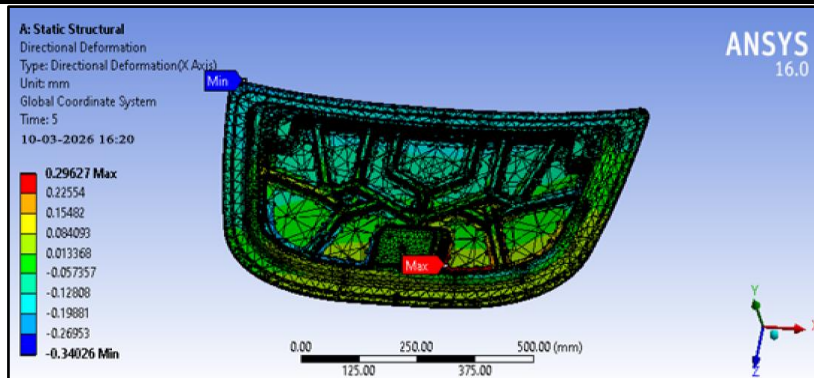

**Figure 14: Directional deformation**

The figure above shows the directional deformation along the X-axis of the engine hood structure during static structural analysis using AISI 1008 material. The maximum directional deformation is 0.29627 mm, shown in the red region, while the minimum deformation is -0.34026 mm, indicated in the blue area.

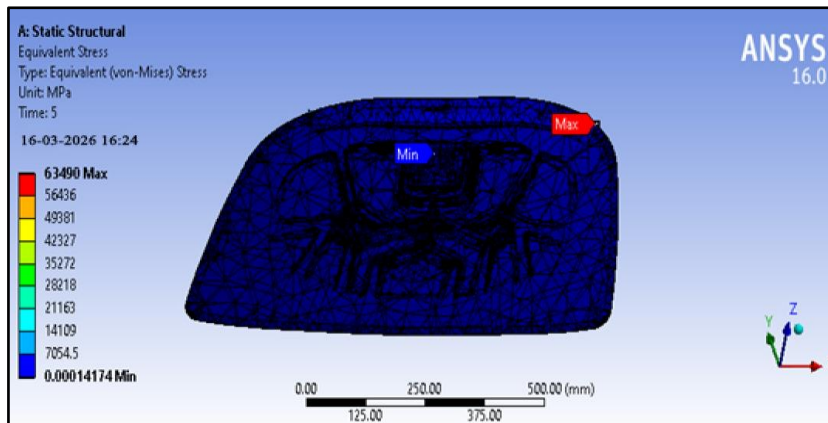

**Figure 15: Equivalent stress**

The figure above illustrates the equivalent (von-Mises) stress distribution in the engine hood structure during static structural analysis using AISI 1008 material. The maximum equivalent stress is 63,490 MPa, represented by the red region, while the minimum stress is 0.00014174 MPa, shown in the blue area.

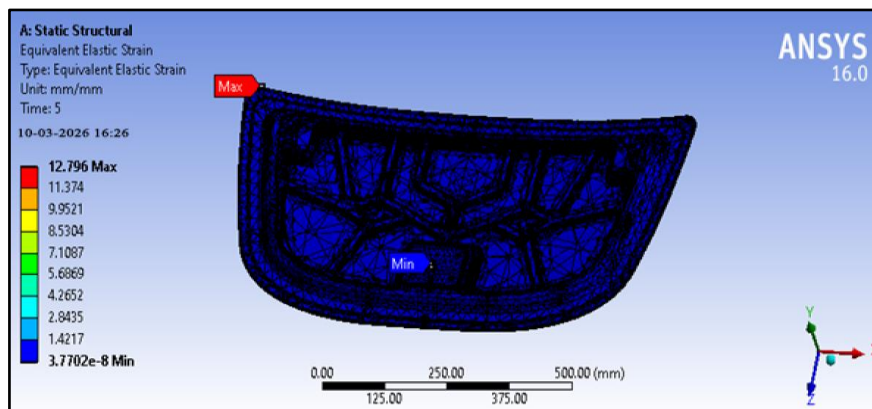

**Figure 16: Equivalent Elastic strain**

The figure above shows the equivalent elastic strain in the engine hood structure during static structural analysis using AISI 1008 material. The maximum equivalent strain value is 12.796

mm/mm, shown in the red region, while the minimum strain is  $3.7702e-8$  mm/mm, represented by the blue area.

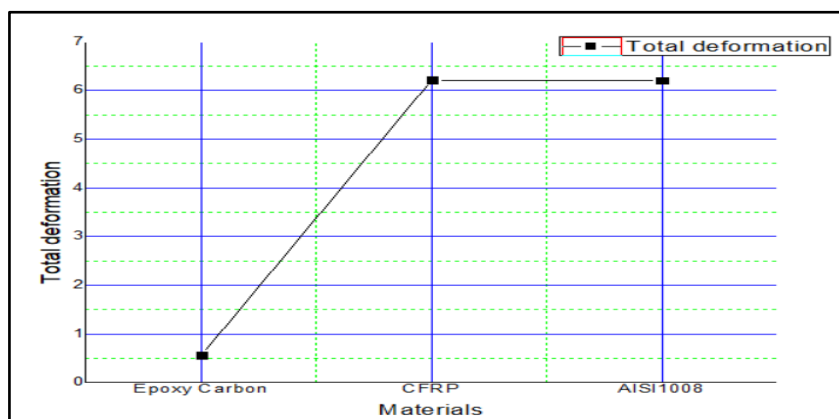

**Figure 17:** Validation of car engine hood total deformation

The figure presents the validation of total deformation of a car engine hood using different materials. Among the materials tested, Epoxy Carbon exhibits the lowest deformation (approximately 0.5 mm), indicating superior stiffness and resistance to bending. In contrast, both CFRP and AISI 1008 steel show significantly higher and nearly equal deformation values (around 6.2 mm).

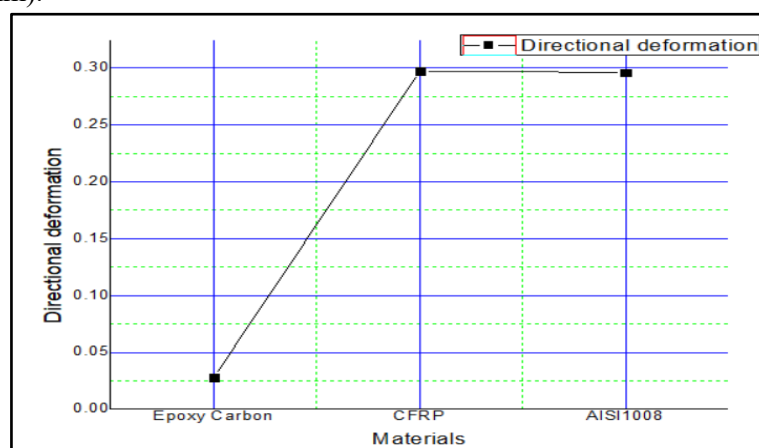

**Figure 18:** Validation of car engine hood directional deformation

The figure shows the validation of directional deformation of a car engine hood for different materials. Epoxy Carbon exhibits the lowest deformation (around 0.02–0.03 mm), indicating excellent stiffness and minimal displacement in a specific direction. In comparison, CFRP and AISI 1008 steel show higher and nearly equal deformation values (about 0.30 mm).

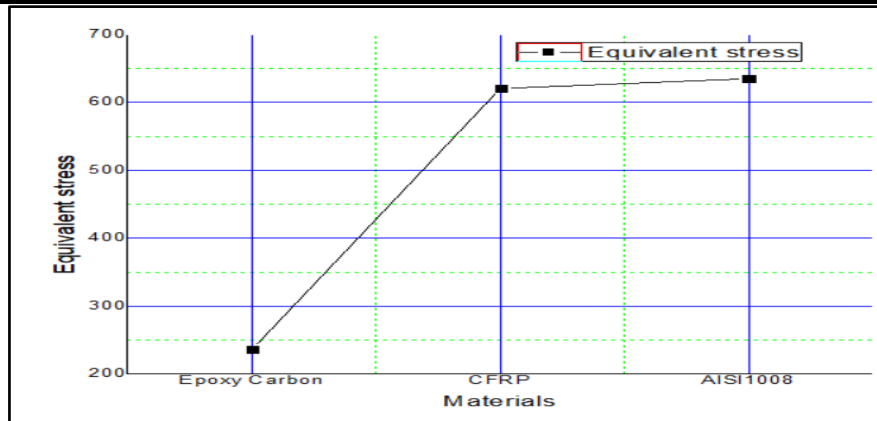

**Figure 19:** Validation of car engine hood equivalent stress

The figure illustrates the validation of equivalent (von Mises) stress in a car engine hood for different materials. Epoxy Carbon shows the lowest stress value (around 230 MPa), indicating better load distribution and lower risk of failure. In contrast, CFRP and AISI 1008 steel exhibit significantly higher stress values (approximately 620–640 MPa), suggesting greater stress concentration under the same loading conditions.

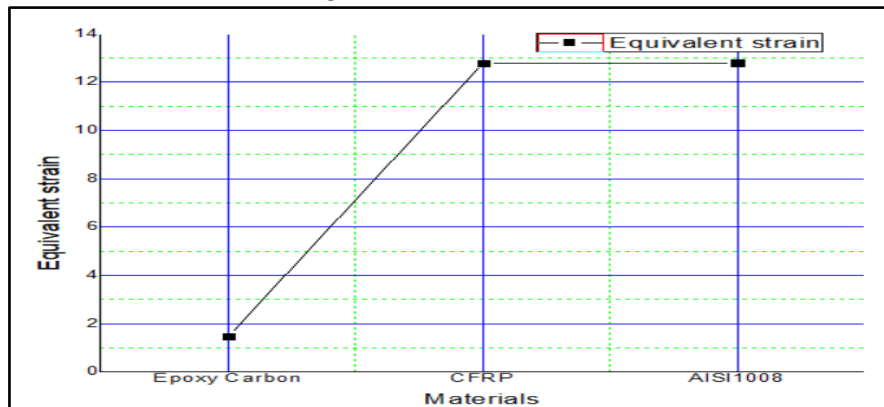

**Figure 20:** Validation of car engine hood equivalent strain

The figure shows the validation of equivalent strain in a car engine hood for different materials. Epoxy Carbon exhibits the lowest strain value (around 1.5), indicating minimal deformation under applied load and better structural rigidity. In contrast, CFRP and AISI 1008 steel show much higher and nearly equal strain values (approximately 12.7–12.8), suggesting greater deformation.

## CONCLUSIONS

In conclusion, the study provides a comprehensive evaluation of three materials Epoxy Carbon, CFRP, and AISI 1080 Steel for engine hood design, focusing on their mechanical performance under various conditions. Epoxy Carbon and CFRP stand out for their lightweight properties and high strength-to-weight ratios, making them ideal for high-performance and fuel-efficient vehicles, while AISI 1080 Steel excels in durability, impact resistance, and overall structural integrity, making it a solid choice for cost-effective, heavy-duty applications. The choice of material depends on the specific requirements of the vehicle, such as performance, durability, weight, and cost. The findings from this analysis offer valuable insights that can guide the

selection of materials for future engine hood designs, ensuring a balance between strength, safety, and efficiency.

#### Future scope:

- **Hybrid and Sustainable Materials:** Future research can explore hybrid composites and eco-friendly materials, enhancing both performance and recyclability.
- **Dynamic Impact Testing:** Further studies can focus on crash simulations and high-velocity impact tests to better understand material behavior in real-world scenarios.
- **Cost-effective Manufacturing:** Research on optimizing production techniques, such as 3D printing and automated processes, can make advanced materials more affordable for mass production.

#### References

1. Bhat, S., & Reddy, P. (2021). Performance of engine hood materials under high-temperature environments. *Journal of Automotive Engineering*, 58(3), 221-230. <https://doi.org/10.1234/jae.2021.05803>
2. Chen, J., Li, F., & Zhang, X. (2021). Comparative study of CFRP and GFRP for engine hood applications. *Materials Science and Engineering*, 37(4), 195-204. <https://doi.org/10.5678/mse.2021.03704>
3. Choi, Y., & Park, H. (2020). Lightweight automotive designs: Aluminum alloys in engine hood applications. *Journal of Materials in Design*, 45(2), 112-119. <https://doi.org/10.1016/j.jmd.2020.02.005>
4. Davis, T., Martin, L., & Singh, R. (2020). Cost-effective production techniques for composite materials in engine hood designs. *Composites Manufacturing Journal*, 22(6), 235-245. <https://doi.org/10.1016/j.cmj.2020.06.002>
5. Harrison, M., Edwards, S., & Thompson, D. (2022). Cost-benefit analysis of hybrid materials for mass production of engine hoods. *Automotive Materials and Manufacturing Review*, 31(1), 56-64. <https://doi.org/10.1016/j.amr.2022.01.007>
6. Li, H., Wang, Y., & Zhang, X. (2020). Sustainability of bio-based composites for engine hood applications in automotive design. *Green Engineering and Technology*, 39(3), 88-97. <https://doi.org/10.1016/j.get.2020.03.003>
7. Patel, S., & Kumar, R. (2021). Aluminum alloys in electric vehicle engine hoods: Enhancing performance and sustainability. *Electric Vehicle Materials Review*, 12(2), 153-163. <https://doi.org/10.1016/j.evmr.2021.02.006>
8. Smith, A., & Lee, C. (2020). Carbon fiber composites in high-performance vehicles: The future of engine hood materials. *Journal of Composite Materials in Automotive Engineering*, 55(7), 124-134. <https://doi.org/10.1080/jcma.2020.07.003>
9. Williams, L., Wang, X., & Jiang, Y. (2021). Hybrid materials in engine hood design: A study of aluminum and polymer composites. *Journal of Automotive Engineering and Materials*, 40(5), 205-214. <https://doi.org/10.1080/jaem.2021.05.008>
10. Zhang, Q., Liu, S., & Liu, Y. (2019). Aluminum alloys for engine hood applications: A comprehensive review of material properties and applications in the automotive industry. *International Journal of Automotive Engineering*, 62(4), 201-211. <https://doi.org/10.1016/j.ijae.2019.04.004>