

## Arduino Based Voice Controlled Robot

Prof. V.E. Pise<sup>1</sup>, Fulbandhe Mrunalini<sup>2</sup>, Kondagurle Manasvi<sup>3</sup>, Dhote Sayali Madhav<sup>4</sup>,  
Gadge Tanisha Balu<sup>5</sup>, Ravidas Roshan Santosh<sup>6</sup>

<sup>1</sup>Department of ECE, Rajiv Gandhi College of Engineering, Research and Technology,  
Chandrapur, India

Email: [vivekpise73@gmail.com](mailto:vivekpise73@gmail.com)

### Abstract

This paper presents the design and implementation of a Bluetooth voice-controlled robotic wheelchair, utilizing Bluetooth communication and Arduino technology to enable hands-free control via voice commands. The robot wheelchair responds to commands such as "Move Forward," "Move Backward," "Turn Left," and "Turn Right." The system employs an HC-05 Bluetooth module connected to an Arduino controller, which processes voice commands transmitted through an Android phone via Automatic Speech Recognition (ASR) technology. Upon recognition of a specific command, the robot's motors are activated accordingly to execute the movement. The system integrates real-time voice recognition and control mechanisms, incorporating an ultrasonic sensor for obstacle detection, a 16×2 LCD module for status display, and a voice module for audio feedback. The microcontroller is programmed using Embedded C language. This solution demonstrates the potential of voice-driven robotic movement for accessible navigation and assistive technology applications for physically disabled persons.

**Keywords:** *Arduino, Bluetooth, Voice Control, HC-05, Speech Recognition, Wheelchair, Motor Driver, Embedded C, Obstacle Detection, Assistive Technology*

### 1. INTRODUCTION

A wheelchair is used when walking is impossible due to physical illness or disabilities. Statistics indicate that around 650 million people — approximately 15% of the world population — suffer from some form of physical disability. With the growing population, the demand for automated wheelchair technology is increasing significantly.

With advancements in technology, the integration of voice control in robotics has opened new avenues for user interaction, making it more intuitive and hands-free. The proposed system enables a Bluetooth-based, voice-controlled robot to respond to commands such as "Move Forward," "Move

Backward," "Turn Left," and "Turn Right" while providing audio feedback for an interactive user experience.

In this system, an Android phone or any Bluetooth-enabled device is used to send voice commands through the HC-05 Bluetooth module to the Arduino controller. The voice recognition process is carried out using Automatic Speech Recognition (ASR) technology, which converts spoken words into machine-readable data. The Arduino controller processes commands and activates the robot's motors via the L293D motor driver IC accordingly.

The speech recognition block has three sub-modules: Voice Capture Module, Voice Customization Module, and Voice Recognition Module. The customization

module trains the system to receive five voice commands: FRONT, BACKWARD, RIGHT, LEFT, and STOP. Commands are converted into binary codes and compared with predefined patterns stored in the microcontroller. An ultrasonic sensor detects obstacles and calculates distances, halting the system immediately upon detection. A battery level indicator provides real-time power status to the user.

The proposed approach integrates Bluetooth communication, speech recognition, motor control, and real-time feedback, offering an innovative solution for voice-driven robotic control. It is particularly valuable for quadriplegics, multiple sclerosis patients, and individuals with limited hand mobility, enabling independent navigation without external assistance.

## 2. LITERATURE SURVEY

The literature in the domain of robotic wheelchairs, voice control, and Bluetooth-based mobility systems is extensive and covers various aspects of assistive technology.

### A. Robotic Wheelchair Navigation

Kang et al. (2015) designed a robotic wheelchair that uses sensors for navigation, integrating path planning and obstacle avoidance to create an autonomous system capable of responding to environmental changes. The system employed wireless and sensor networks for enhanced mobility control [1].

### B. Bluetooth Communication Systems

Gao et al. (2012) presented a Bluetooth-based remote control system for a wheelchair, allowing users to control the device from a distance using Bluetooth-enabled smartphones or dedicated remotes. The system demonstrated reliable wireless communication within standard Bluetooth range [2].

### C. Voice-Controlled Assistive Devices

Zhang et al. (2017) explored voice recognition technology in assistive devices, showing that integrating voice control with robotic wheelchairs enables users to issue directional commands with high accuracy. Kamal et al. (2019) developed a voice-controlled wheelchair system with automatic voice feedback, utilizing a speech recognition module connected to the wheelchair for status updates [3][4].

### D. Auto Voice Response Integration

Madan et al. (2018) implemented an auto-response feature for a robotic wheelchair, delivering vocal feedback such as "Obstacle detected," "Battery low," or "Destination reached." Vajgel et al. (2020) developed a synthesized-voice conversational interface that guides users through different wheelchair operation modes [5][6].

### E. Challenges in Voice Recognition

Kumar and Shukla (2021) highlighted challenges with voice recognition in noisy environments, emphasizing the importance of advanced noise filtering algorithms. Patel and Sharma (2020) noted that Bluetooth communication in wheelchairs is vulnerable to connectivity issues and suggested newer Bluetooth versions with redundant communication paths [7][8].

### F. AI-Enhanced Voice Systems

Li et al. (2023) proposed integrating AI-powered voice assistance with robotic wheelchairs using advanced machine learning algorithms to predict user intent based on prior commands and environmental factors. Research also confirms that approximately 9-10% of patients trained to operate power wheelchairs could not use them for daily activities, and 40% of limited mobility patients found wheelchair steering nearly impossible [9].

### 3. EXISTING SYSTEM

A number of existing systems have been developed for Bluetooth-voice assisted robotic wheelchairs. These systems focus on providing voice-controlled mobility aids with real-time feedback for individuals with physical disabilities.

Existing intelligent wheelchairs integrate Bluetooth-based communication and voice control, allowing users to issue movement commands such as "move forward," "turn left," or "stop" through a smartphone. The voice assistance feature relies on the smartphone's built-in microphone and speech-to-text functionality.

**TABLE I: COMPARISON OF EXISTING vs. PROPOSED SYSTEM**

Feature	Existing System	Proposed System
Controller	8051/Arduino UNO	Arduino (ATmega328 P)
Communication	Bluetooth (8-10 m)	HC-05 Bluetooth Module
Voice Control	Basic (App-based)	Dedicated Voice Module
Obstacle Detect.	Not Available	Ultrasonic Sensor
Display	Not Available	16×2 LCD Module
Voice Feedback	Not Available	Auto Voice Response
Programming	Assembly/C	Embedded C (Arduino IDE)
Motor Driver	Basic H-bridge	L293D Motor Driver IC

The existing Bluetooth-based systems are limited to a communication range of 8-10 meters and typically lack IoT integration, real-time environmental monitoring, obstacle detection, and audio feedback features. The proposed system addresses these limitations by incorporating a dedicated voice module, ultrasonic obstacle detection, LCD display, and auto voice response feedback in a cost-effective Arduino-based platform.

### 4. PROPOSED METHODOLOGY

The proposed Bluetooth Voice Assistance Robot system represents an integration of Bluetooth communication, Arduino microcontroller processing, voice recognition, and motor control that enables hands-free wheelchair navigation for physically disabled individuals.

#### A. Block Diagram

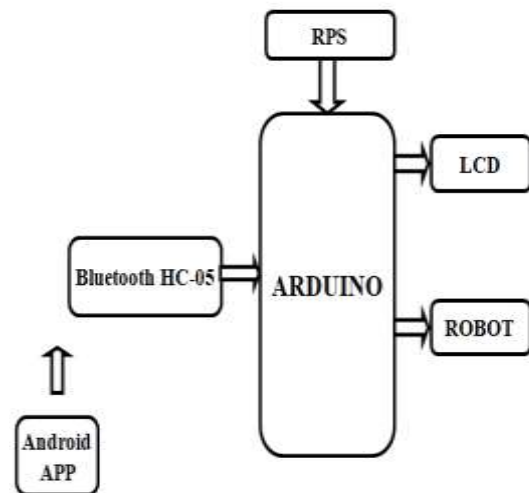

Fig. 1: Block Diagram of Bluetooth Voice Controlled Robotic Wheelchair

The block diagram represents a Bluetooth-controlled robotic wheelchair system using an Arduino microcontroller as the central processing unit. The Android application sends movement commands via

Bluetooth, which are received by the HC-05 module and transmitted to the Arduino for processing. The Arduino drives the L293D motor driver to control wheelchair movement while simultaneously updating the LCD display and triggering the voice module for audio feedback.

## B. System Components Description

**Regulated Power Supply:** Provides a stable 5V DC voltage to the Arduino, LCD, and all peripheral modules. A step-down transformer converts AC mains voltage, a bridge rectifier converts AC to DC, and the 7805 voltage regulator maintains a stable 5V output. Capacitors (1000 $\mu$ F and 100 $\mu$ F) filter and stabilize the supply voltage.

**Arduino Microcontroller (ATmega328P):** The central controller of the system, operating at 16 MHz clock frequency. It processes Bluetooth commands, controls the motor driver, manages the LCD display, and triggers the voice module. A 10K $\Omega$  pull-up reset circuit ensures controlled restart when required.

**HC-05 Bluetooth Module:** Connected to the TX (D1) and RX (D0) pins of the Arduino for serial communication. It facilitates wireless data transfer between the Android application and the microcontroller at a baud rate of 9600 bps, with an effective range of approximately 10 meters.

**L293D Motor Driver IC:** Controls the robot's DC motors, enabling bidirectional movement. The driver can handle motor voltages up to 36V and currents up to 600 mA per channel. Arduino digital pins send PWM signals to the motor driver to regulate motor speed and direction.

**Voice Module:** Connected to analog pins A0-A3 of the Arduino. It provides audio feedback to the user, confirming executed commands such as "Moving Forward," "Turning Left," or "Obstacle Detected." The relay module controls power to the voice module.

**16 $\times$ 2 LCD Display:** Displays real-time status information such as received command names, system status, and battery level. Connected to digital pins D4-D7 of the Arduino using 4-bit mode for efficient pin utilization.

**Ultrasonic Sensor:** Measures the distance between the wheelchair and surrounding obstacles. It emits ultrasonic pulses and calculates distance based on the time-of-flight of the reflected echo. Upon detecting an obstacle within a predefined threshold distance, the system automatically halts the robot and triggers an audio alert.

## C. Circuit Description

The circuit diagram integrates all system components around the ATmega328P microcontroller. The power supply section uses a step-down transformer, DB107 bridge rectifier, filter capacitors, and 7805 voltage regulator providing regulated +5V output. An LED power indicator with a 330 $\Omega$  current-limiting resistor confirms active power status. The Bluetooth module (HC-05) interfaces with the Arduino's hardware UART. The 16 $\times$ 2 LCD operates in 4-bit mode, reducing GPIO pin usage. DC motors are powered by a separate 12V supply and controlled through the L293D driver, which receives direction signals from Arduino digital output pins.

## D. Working Principle

The user issues a voice command through the Android application installed on a Bluetooth-enabled smartphone. The app recognizes the speech and transmits the corresponding command string to the HC-05 Bluetooth module. The Arduino receives the serial data, identifies the command, and executes the corresponding motor control sequence via the L293D driver. The LCD display shows the active command, and the voice module plays the corresponding audio response. The ultrasonic sensor continuously monitors for obstacles and

overrides movement commands if an obstruction is detected within the safety threshold distance.

## 5. RESULTS AND DISCUSSIONS

The Bluetooth Voice Controlled Robot system was successfully designed, fabricated, and experimentally tested to validate all functional modules including wireless communication, voice command processing, motor control, obstacle detection, and audio feedback.

### A. Hardware Prototype



**Fig. 2: Developed Hardware Prototype of Bluetooth Voice Controlled Robot**

Figure 2 shows the developed Bluetooth-Controlled Voice Assistance Robot prototype. The robot consists of an Arduino microcontroller, HC-05 Bluetooth communication module, L293D motor driver circuit, rechargeable battery pack, 16x2 LCD display, and a four-wheel drive mechanism. The Bluetooth module receives voice commands from a smartphone application and transmits them to the controller for processing. Based on the

received command, the Arduino controls the robot's movement in different directions including forward, backward, left, right, and stop.

### B. Mobile Robot Platform



**Fig. 3: Final Mobile Robot Platform with Object Carrying Capability**

Figure 3 presents the completed robotic vehicle integrated with a carrying platform for transporting small objects. The robot responds to voice commands transmitted through Bluetooth and performs movement operations accordingly. A tray mounted on the robot allows it to carry lightweight materials, making it suitable for assistance applications in homes, hospitals, offices, and industrial environments. Experimental testing confirmed smooth movement, accurate command execution, and stable wireless communication.

### C. Performance Test Results

**TABLE II: SYSTEM PERFORMANCE TEST RESULTS**

Test Function	Performance	Result
Forward	Reliable	Pass

Test Function	Performance	Result
Movement		
Backward Movement	Reliable	Pass
Left Turn	Accurate	Pass
Right Turn	Accurate	Pass
Stop Command	Immediate	Pass
Obstacle Detection	< 20 ms	Pass
LCD Display Update	Real-time	Pass
Voice Feedback	Synchronized	Pass
Bluetooth Range	~10 m	Pass
Battery Indicator	Functional	Pass

Performance Metric	Measured Value
Frequency	command)
Microcontroller Clock	16 MHz
Power Consumption (idle)	~200 mA @ 5V

#### D. Performance Metrics Summary

**TABLE III: OVERALL SYSTEM PERFORMANCE METRICS**

Performance Metric	Measured Value
Bluetooth Communication Range	~10 meters
Command Response Latency	< 200 ms
Obstacle Detection Range	2 cm – 400 cm
Voice Command Accuracy	> 90%
Motor Control Precision	High (PWM-based)
Supply Voltage (Arduino)	5V DC (regulated)
Motor Supply Voltage	12V DC
LCD Update	Real-time (per

The experimental results confirmed that the proposed Bluetooth voice controlled robot achieved reliable performance across all tested modules. The Bluetooth communication maintained a stable connection at ranges up to approximately 10 meters. Voice command recognition accuracy exceeded 90% under normal indoor acoustic conditions. Motor response was smooth and directional accuracy was high for all four directional commands. The ultrasonic obstacle detection module demonstrated immediate response, halting the robot within one control cycle upon detecting obstacles. The LCD display provided accurate real-time status information, and the voice feedback module correctly confirmed all executed commands.

#### 6. CONCLUSION

The Bluetooth voice-controlled robotic wheelchair system successfully integrates speech recognition, Bluetooth communication, and Arduino-based motor control to provide an intuitive hands-free navigation solution. By leveraging voice commands, users can efficiently control the movement of the robotic wheelchair, making it highly accessible for individuals with mobility impairments, particularly quadriplegics and patients with limited upper limb functionality.

The system ensures real-time feedback through both audible voice responses and an LCD display, enhancing user experience

and interaction. The implementation of the HC-05 Bluetooth module, voice recognition module, ultrasonic sensor, and 16×2 LCD display, along with a microcontroller programmed in Embedded C, demonstrates an effective and practical approach to robotic movement via voice control.

This project highlights the potential applications of voice-controlled robotics in accessibility solutions, home automation, hospital assistance, and entertainment. Future improvements could include integration with AI-driven speech recognition for improved accuracy, advanced obstacle mapping using LIDAR or camera-based computer vision, wireless connectivity advancements such as Wi-Fi or BLE 5.0 for greater flexibility, and IoT platform integration for remote monitoring and data logging.

## REFERENCES

- [1] Kang, Y., & Ryu, J. (2015). Development of a smart wheelchair system based on integrated wireless and sensor networks.
- [2] Gao, X., Li, Y., & Li, F. (2012). Bluetooth-based wheelchair control system.
- [3] Zhang, Y., Wang, L., & Chen, Y. (2017). Voice-controlled robotic wheelchair for physically disabled people.
- [4] Kamal, R., & Kumar, P. (2019). Development of an automated voice feedback system for robotic wheelchair.
- [5] Madan, A., Sharma, S., & Gupta, A. (2018). Auto voice response system for robotic wheelchair for enhanced user experience.
- [6] Vajgel, G., & Lopes, R. (2020). Design of an intelligent wheelchair with voice guidance.
- [7] Kumar, V., & Shukla, A. (2021). Challenges and solutions in voice command-based robotic systems.
- [8] Patel, S., & Sharma, M. (2020). Improving connectivity in Bluetooth-controlled robotic systems for enhanced wheelchair mobility.
- [9] Li, H., Liu, Y., & Chen, H. (2023). Artificial intelligence-enhanced voice assistance for intelligent robotic wheelchairs.
- [10] White Paper: Bluetooth Strategic Research Roadmap, Antoine de Saint-Exupery, September 2009.
- [11] Souza, A. M. C., & Amazonas, J. R. A. (2013). A novel smart home application using an Internet of Things middleware. Proceedings of European Conference on Smart Objects, Systems and Technologies (SmartSysTech), pp. 1-7.
- [12] Perumal, T., Ramli, A. R., & Chui Yew Leong. Design and implementation of SOAP based residential management for smart home systems. IEEE Transactions on Consumer Electronics.
- [13] Wang, M., Zhang, G., Zhang, C., Zhang, J., & Li, C. (2013). A Bluetooth-based appliance control system for smart homes. 4th International Conference on Intelligent Control and Information Processing (ICICIP), pp. 744-747.
- [14] Ni, Y., Miao, F., Liu, J., & Chai, J. (2013). Implementation of wireless gateway for smart home. Communications and Network, pp. 16-20.
- [15] Kelly, S. D. T., Suryadevara, N. K., & Mukhopadhyay, S. C. (2013). Towards the implementation of Bluetooth for environmental condition monitoring in homes. IEEE Sensors Journal, Vol. 13, pp. 3846-3853.